









Concepts of Perimeter and Area

Ex 21A

Perimeter

<p>• Square:</p>  <p>Perimeter = $4a$</p>	<p>• Circle</p>  <p>Perimeter = $2 \times \pi \times r$</p>
<p>• Rectangle:</p>  <p>Perimeter = $2a + 2b$</p>	<p>• Parallelogram:</p>  <p>Perimeter = $2a + 2b$</p>
<p>• Triangle:</p>  <p>Perimeter = $a + b + c$</p>	<p>• Trapezoid:</p>  <p>Perimeter = $a + b + c + d$ $= 2m + c + d$</p>
<p>• Rhombus:</p>  <p>Perimeter = $4a$</p>	<p>• Regular N-gon:</p>  <p>Perimeter = ns, $n = \#$ of sides</p>
<p>• Ellipse:</p>  <p>Perimeter = $2\pi \sqrt{\frac{a^2 + b^2}{2}}$</p>	

Q1

Answer :

Perimeter of a rectangle = $2 \times (\text{Length} + \text{Breadth})$

(i) Length = 16.8 cm

Breadth = 6.2 cm

$$\begin{aligned} \text{Perimeter} &= 2 \times (\text{Length} + \text{Breadth}) \\ &= 2 \times (16.8 + 6.2) = 46 \text{ cm} \end{aligned}$$

(ii) Length = 2 m 25 cm

$$\begin{aligned} &= (200+25) \text{ cm} \quad (1 \text{ m} = 100 \text{ cm}) \\ &= 225 \text{ cm} \end{aligned}$$

Breadth = 1 m 50 cm

$$\begin{aligned} &= (100+50) \text{ cm} \quad (1 \text{ m} = 100 \text{ cm}) \\ &= 150 \text{ cm} \end{aligned}$$

Perimeter = $2 \times (\text{Length} + \text{Breadth})$

$$= 2 \times (225 + 150) = 750 \text{ cm}$$

(iii) Length = 8 m 5 dm

$$\begin{aligned} &= (80+5) \text{ dm} \quad (1 \text{ m} = 10 \text{ dm}) \\ &= 85 \text{ dm} \end{aligned}$$

Breadth = 6 m 8 dm

$$\begin{aligned} &= (60+8) \text{ dm} \quad (1 \text{ m} = 10 \text{ dm}) \\ &= 68 \text{ dm} \end{aligned}$$

Perimeter = $2 \times (\text{Length} + \text{Breadth})$

$$= 2 \times (85 + 68) = 306 \text{ dm}$$

Q2

Answer :

Length of the field = 62 m

Breadth of the field = 33 m

Perimeter of the field = $2(l + b)$ units

$$= 2(62 + 33) \text{ m} = 190 \text{ m}$$

Q3

Cost of fencing per metre = Rs 16

Total cost of fencing = Rs (16×190) = Rs 3040

Answer :

Let the length of the rectangle be $5x$ m.

Breadth of the rectangle = $3x$ m

$$\begin{aligned}\text{Perimeter of the rectangle} &= 2(l + b) \\ &= 2(5x + 3x) \text{ m} \\ &= (16x) \text{ m}\end{aligned}$$

It is given that the perimeter of the field is 128 m.

$$\therefore 16x = 128$$

$$\Rightarrow x = \frac{128}{16} = 8$$

$$\therefore \text{Length} = (5 \times 8) = 40 \text{ m}$$

$$\text{Breadth} = (3 \times 8) = 24 \text{ m}$$

Q4

Answer :

Total cost of fencing = Rs 1980

Rate of fencing = Rs 18 per metre

$$\text{Perimeter of the field} = \frac{\text{Total cost}}{\text{Rate}} = \frac{\text{Rs } 1980}{\text{Rs } 18/\text{m}} = \left(\frac{1980}{18}\right) \text{ m} = 110 \text{ m}$$

Let the length of the field be x metre.

Perimeter of the field = $2(x + 23)$ m

$$\therefore 2(x + 23) = 110$$

$$\Rightarrow (x + 23) = 55$$

$$x = (55 - 23) = 32$$

Hence, the length of the field is 32 m.

Q5

Answer :

Total cost of fencing = Rs 3300

Rate of fencing = Rs 25/m

$$\text{Perimeter of the field} = \frac{\text{Total cost}}{\text{Rate of fencing}} = \left(\frac{\text{Rs } 3300}{\text{Rs } 25/\text{m}}\right) = \frac{3300}{25} \text{ m} = 132 \text{ m}$$

Let the length and the breadth of the rectangular field be $7x$ and $4x$, respectively.

Perimeter of the field = $2(7x + 4x) = 22x$

It is given that the perimeter of the field is 132 m.

$$\therefore 22x = 132$$

$$\Rightarrow x = \frac{132}{22} = 6$$

$$\therefore \text{Length of the field} = (7 \times 6) \text{ m} = 42 \text{ m}$$

$$\text{Breadth of the field} = (4 \times 6) \text{ m} = 24 \text{ m}$$

Q6

Answer :

(i) Side of the square = 3.8 cm

$$\begin{aligned}\text{Perimeter of the square} &= (4 \times \text{side}) \\ &= (4 \times 3.8) = 15.2 \text{ cm}\end{aligned}$$

(ii) Side of the square = 4.6 cm

$$\begin{aligned}\text{Perimeter of the square} &= (4 \times \text{side}) \\ &= (4 \times 4.6) = 18.4 \text{ cm}\end{aligned}$$

(iii) Side of the square = 2 m 5 dm

$$\begin{aligned}&= (20+5) \text{ dm} \quad (1 \text{ m} = 10 \text{ dm}) \\ &= 25 \text{ dm}\end{aligned}$$

$$\begin{aligned}\text{Perimeter of the square} &= (4 \times \text{side}) \\ &= (4 \times 25) = 100 \text{ dm}\end{aligned}$$

Q7

Answer :

Total cost of fencing = Rs 4480

Rate of fencing = Rs 35/m

$$\text{Perimeter of the field} = \frac{\text{Total cost}}{\text{Rate}} = \frac{\text{Rs } 4480}{\text{Rs } 35/\text{m}} = \frac{4480}{35} \text{ m} = 128 \text{ m}$$

Let the length of each side of the field be x metres.

Perimeter = $(4x)$ metres

$$\therefore 4x = 128$$

$$\Rightarrow x = \frac{128}{4} = 32$$

Hence, the length of each side of the field is 32 m.

Q8

Answer :

Side of the square field = 21 m

$$\begin{aligned} \text{Perimeter of the square field} &= (4 \times 21) \text{ m} \\ &= 84 \text{ m} \end{aligned}$$

Let the length and the breadth of the rectangular field be $4x$ and $3x$, respectively.

$$\text{Perimeter of the rectangular field} = 2(4x + 3x) = 14x$$

Perimeter of the rectangular field = Perimeter of the square field

$$\therefore 14x = 84$$

$$\Rightarrow x = \frac{84}{14} = 6$$

$$\therefore \text{Length of the rectangular field} = (4 \times 6) \text{ m} = 24 \text{ m}$$

$$\text{Breadth of the rectangular field} = (3 \times 6) \text{ m} = 18 \text{ m}$$

Q9

Answer :

(i) Sides of the triangle are 7.8 cm, 6.5 cm and 5.9 cm.

$$\begin{aligned} \text{Perimeter of the triangle} &= (\text{First side} + \text{Second side} + \text{Third Side}) \text{ cm} \\ &= (7.8 + 6.5 + 5.9) \text{ cm} \\ &= 20.2 \text{ cm} \end{aligned}$$

(ii) In an equilateral triangle, all sides are equal.

Length of each side of the triangle = 9.4 cm

$$\begin{aligned} \therefore \text{Perimeter of the triangle} &= (3 \times \text{Side}) \text{ cm} \\ &= (3 \times 9.4) \text{ cm} \\ &= 28.2 \text{ cm} \end{aligned}$$

(iii) Length of two equal sides = 8.5 cm

Length of the third side = 7 cm

$$\begin{aligned} \therefore \text{Perimeter of the triangle} &= \{(2 \times \text{Equal sides}) + \text{Third side}\} \text{ cm} \\ &= \{(2 \times 8.5) + 7\} \text{ cm} \\ &= 24 \text{ cm} \end{aligned}$$

Q10

Answer :

(i) Length of each side of the given pentagon = 8 cm

$$\begin{aligned} \therefore \text{Perimeter of the pentagon} &= (5 \times 8) \text{ cm} \\ &= 40 \text{ cm} \end{aligned}$$

(ii) Length of each side of the given octagon = 4.5 cm

$$\begin{aligned} \therefore \text{Perimeter of the octagon} &= (8 \times 4.5) \text{ cm} \\ &= 36 \text{ cm} \end{aligned}$$

(iii) Length of each side of the given decagon = 3.6 cm

$$\begin{aligned} \therefore \text{Perimeter of the decagon} &= (10 \times 3.6) \text{ cm} \\ &= 36 \text{ cm} \end{aligned}$$

Q11

Answer :

- (i) Perimeter of the figure = Sum of all the sides
= $(27 + 35 + 35 + 45)$ cm
= 142 cm
- (ii) Perimeter of the figure = Sum of all the sides
= $(18 + 18 + 18 + 18)$ cm
= 72 cm
- (iii) Perimeter of the figure = Sum of all the sides
= $(8 + 16 + 4 + 12 + 12 + 16 + 4)$ cm
= 72 cm

bodhiyla.com

Concepts of Perimeter and Area

Ex 21B

Q1

Answer :

(i) Radius, $r = 28$ cm

$$\begin{aligned} \therefore \text{Circumference of the circle, } C &= 2\pi r \\ &= \left(2 \times \frac{22}{7} \times 28\right) \\ &= 176 \text{ cm} \end{aligned}$$

Hence, the circumference of the given circle is 176 cm.

(ii) Radius, $r = 10.5$ cm

$$\begin{aligned} \therefore \text{Circumference of the circle, } C &= 2\pi r \\ &= \left(2 \times \frac{22}{7} \times 10.5\right) \\ &= 66 \text{ cm} \end{aligned}$$

Hence, the circumference of the given circle is 66 cm.

(iii) Radius, $r = 3.5$ m

$$\begin{aligned} \therefore \text{Circumference of the circle, } C &= 2\pi r \\ &= \left(2 \times \frac{22}{7} \times 3.5\right) \\ &= 22 \text{ m} \end{aligned}$$

Hence, the circumference of the given circle is 22 m.

Q2

Answer :

(i)

$$\begin{aligned} \text{Circumference} &= 2\pi r &&= \pi(2r) &&= \pi \times \text{Diameter of the} \\ \text{circle (d)} &&& \left(\text{Diameter} = 2 \times \text{radius}\right) && \end{aligned}$$

\Rightarrow Circumference = Diameter $\times \pi$ Diameter of the given circle is 14 cm.

$$\text{Circumference of the given circle} = 14 \times \pi \Rightarrow \left(14 \times \frac{22}{7}\right) = 44 \text{ cm}$$

Circumference of the given circle is 44 cm.

(ii)

$$\begin{aligned} \text{Circumference} &= 2\pi r &&= \pi(2r) &&= \pi \times \text{Diameter of the} \\ \text{circle (d)} &&& \left(\text{Diameter} = 2 \times \text{Radius}\right) && \end{aligned}$$

\Rightarrow Circumference = Diameter $\times \pi$ Diameter of the given circle is 35 cm.

$$\Rightarrow \text{Circumference of the given circle} = 35 \times \pi \Rightarrow \left(35 \times \frac{22}{7}\right) = 110 \text{ cm}$$

Circumference of the given circle is 110 cm.

(iii)

$$\begin{aligned} \text{Circumference} &= 2\pi r &&= \pi(2r) &&= \pi \times \text{Diameter of the} \\ \text{circle (d)} &&& \left(\text{Diameter} = 2 \times \text{Radius}\right) && \end{aligned}$$

\Rightarrow Circumference = Diameter $\times \pi$ Diameter of the given circle is 10.5 m.

$$\text{Circumference of the given circle} = 10.5 \times \pi \Rightarrow \left(10.5 \times \frac{22}{7}\right) = 33 \text{ m}$$

Circumference of the given circle is 33 m.

Q3

Answer :

Let the radius of the given circle be r cm.

Circumference of the circle = 176 cm

Circumference = $2\pi r$

$$\therefore 2\pi r = 176$$

$$\Rightarrow r = \frac{176}{2\pi}$$

$$\Rightarrow r = \left(\frac{176}{2} \times \frac{7}{22} \right)$$

$$\Rightarrow r = 28$$

The radius of the given circle is 28 cm.

Q4

Answer :

Let the radius of the circle be r cm.

Diameter = $2 \times$ Radius = $2r$ cm

Circumference of the wheel = 264 cm

Circumference of the wheel = $2\pi r$

$$\therefore 2\pi r = 264$$

$$\Rightarrow 2r = \frac{264}{\pi}$$

$$\Rightarrow 2r = \left(264 \times \frac{7}{22} \right)$$

$$\Rightarrow 2r = 84$$

Diameter of the given wheel is 84 cm.

Q5

Answer :

Radius of the wheel = $\frac{\text{Diameter of the wheel}}{2}$

$$\Rightarrow r = \frac{77}{2} \text{ cm}$$

Circumference of the wheel = $2\pi r$

$$= \left(2 \times \frac{22}{7} \times \frac{77}{2} \right)$$

$$= 242 \text{ cm}$$

In 1 revolution the wheel covers a distance equal to its circumference.

\therefore Distance covered by the wheel in 1 revolution = 242 cm

\therefore Distance covered by the wheel in 500 revolutions = (500×242) cm

$$= 121000 \text{ cm}$$

$$= 1210 \text{ m} \quad (100 \text{ cm} = 1 \text{ m})$$

$$= 1.21 \text{ km} \quad (1000 \text{ m} = 1 \text{ km})$$

Q6

Answer :

Radius of the wheel (r) = $\frac{\text{Diameter of the wheel}}{2}$

$$r = \frac{70}{2} \text{ cm} = 35 \text{ cm}$$

Circumference of the wheel = $2\pi r = \left(2 \times \frac{22}{7} \times 35 \right)$

$$= 220 \text{ cm}$$

In one revolution, the wheel covers the distance equal to its circumference.

\therefore 220 cm distance = 1 revolution

\therefore 1 cm distance = $\frac{1}{220}$ revolution

\therefore 1 km (or 100000 cm) distance = $\frac{1 \times 100000}{220}$ revolution (\therefore 1 km = 100000 cm)

\therefore 1.65 km distance = $\frac{1.65 \times 100000}{220}$ revolutions

$$= 750 \text{ revolutions}$$

Thus, the wheel will make 750 revolutions to travel 1.65 km.

Concepts of Perimeter and Area

Ex 21C

Q1

Answer :

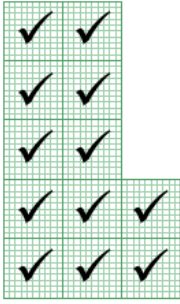

The figure contains 12 complete squares.

Area of 1 small square = 1 sq cm

$$\begin{aligned} \text{Q2 } \therefore \text{ Area of the figure} &= \text{Number of complete squares} \times \text{Area of the square} \\ &= (12 \times 1) \text{ sq cm} \\ &= 12 \text{ sq cm} \end{aligned}$$

Answer :

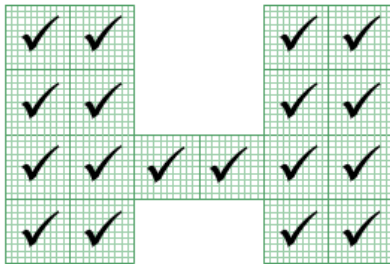

The figure contains 18 complete squares.

Area of 1 small square = 1 sq cm

$$\begin{aligned} \text{Q3 } \therefore \text{ Area of the figure} &= \text{Number of complete squares} \times \text{Area of the square} \\ &= (18 \times 1) \text{ sq cm} \\ &= 18 \text{ sq cm} \end{aligned}$$

Answer :

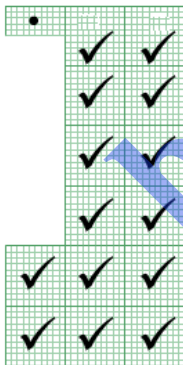

The figure contains 14 complete squares and 1 half square.

Area of 1 small square = 1 sq cm

$$\text{Q4 } \therefore \text{ Area of the figure} = \text{Number of squares} \times \text{Area of the square}$$

Answer :

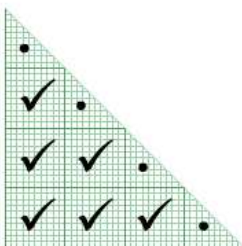

The figure contains 6 complete squares and 4 half squares.

Area of 1 small square = 1 sq cm

\therefore Area of the figure = Number of squares \times Area of the square

$$= \left[(6 \times 1) + \left(4 \times \frac{1}{2} \right) \right] \text{ sq cm}$$

Q5

$$= 8 \text{ sq cm}$$

Answer :

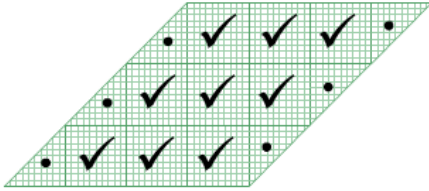

The figure contains 9 complete squares and 6 half squares.

Area of 1 small square = 1 sq cm

$$\begin{aligned}\therefore \text{Area of the figure} &= \text{Number of squares} \times \text{Area of the square} \\ &= \left[(9 \times 1) + \left(6 \times \frac{1}{2} \right) \right] \text{ sq cm} \\ &= 12 \text{ sq cm}\end{aligned}$$

Q6

Answer :

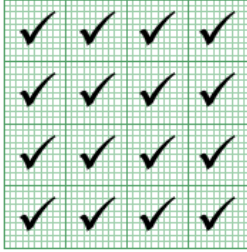

The figure contains 16 complete squares.

Area of 1 small square = 1 sq cm

$$\begin{aligned}\therefore \text{Area of the figure} &= \text{Number of squares} \times \text{Area of a square} \\ &= (16 \times 1) \text{ sq cm} \\ &= 16 \text{ sq cm}\end{aligned}$$

Q7

Answer :

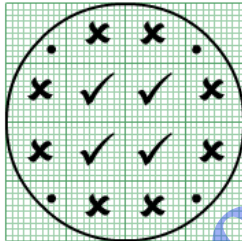

In the given figure, there are 4 complete squares, 8 more than half parts of squares and 4 less than half parts of squares.

We neglect the less than half parts and consider each more than half part of the square as a complete square.

$$\begin{aligned}\therefore \text{Area} &= (4 + 8) \text{ sq cm} \\ &= 12 \text{ sq cm}\end{aligned}$$

Q8

Answer :

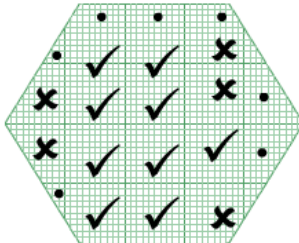

In the given figure, there are 9 complete squares, 5 more than half parts of squares and 7 less than half parts of squares.

We neglect the less than half parts of squares and consider the more than half squares as complete squares.

$$\begin{aligned}\therefore \text{Area of the figure} &= (9 + 5) \text{ sq cm} \\ &= 14 \text{ sq cm}\end{aligned}$$

Q9

Answer :

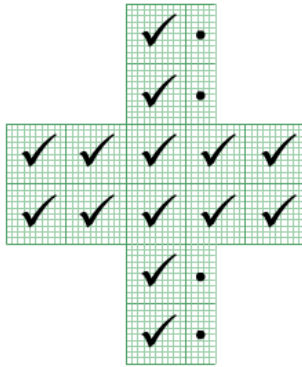

The figure contains 14 complete squares and 4 half squares.

Area of 1 small square = 1 sq cm

Area of the figure = Number of squares \times Area of one square

$$= \left[(14 \times 1) + \left(4 \times \frac{1}{2} \right) \right] \text{sq cm}$$







$$= 16 \text{ sq cm}$$

bodhiyla.com



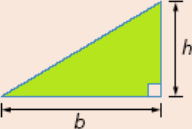

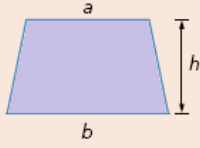
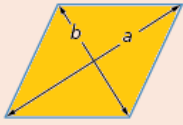

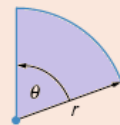

Concepts of Perimeter and Area

Ex 21D

The area of a shape is a measure of the size of its surface.

Square Area = l^2	Rectangle Area = $l \times w$	Triangle Area = $\frac{1}{2} b \times h$	Parallelogram Area = $b \times h$
			
Trapezium Area = $\frac{1}{2} (a + b)h$	Rhombus Area = $\frac{1}{2} a \times b$	Circle Area = πr^2	Sector Area = $\frac{\theta}{360} \pi r^2$
			

Perimeter

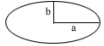
<p>• Square:</p>  <p style="text-align: center;">Perimeter = $4a$</p>	<p>• Circle</p>  <p style="text-align: center;">Perimeter = $2 \times \pi \times r$</p>
<p>• Rectangle:</p>  <p style="text-align: center;">Perimeter = $2a + 2b$</p>	<p>• Parallelogram:</p>  <p style="text-align: center;">Perimeter = $2a + 2b$</p>
<p>• Triangle:</p>  <p style="text-align: center;">Perimeter = $a + b + c$</p>	<p>• Trapezoid:</p>  <p style="text-align: center;">Perimeter = $a + b + c + d$ = $2m + c + d$</p>
<p>• Rhombus:</p>  <p style="text-align: center;">Perimeter = $4a$</p>	<p>• Regular N-gon:</p>  <p style="text-align: center;">Perimeter = ns, $n = \#$ of sides</p>
<p>• Ellipse:</p>  <p style="text-align: center;">Perimeter = $2\pi \sqrt{\frac{a^2 + b^2}{2}}$</p>	

Q1

Answer :

(i) Length = 46 cm

Breadth = 25 cm

$$\begin{aligned} \text{Area of the rectangle} &= (\text{Length} \times \text{Breadth}) \text{ sq units} \\ &= (46 \times 25) \text{ cm}^2 = 1150 \text{ cm}^2 \end{aligned}$$

(ii) Length = 9 m

Breadth = 6 m

$$\begin{aligned} \text{Area of the rectangle} &= (\text{Length} \times \text{Breadth}) \text{ sq units} \\ &= (9 \times 6) \text{ m}^2 = 54 \text{ m}^2 \end{aligned}$$

(iii) Length = 14.5 m

Breadth = 6.8 m

$$\begin{aligned} \text{Area of the rectangle} &= (\text{Length} \times \text{Breadth}) \text{ sq units} \\ &= \left(\frac{145}{10} \times \frac{68}{10}\right) \text{ m}^2 = \frac{9860}{100} \text{ m}^2 = 98.60 \text{ m}^2 \end{aligned}$$

(iv) Length = 2 m 5 cm

$$= (200+5) \text{ cm} \quad (1 \text{ m} = 100 \text{ cm})$$

$$= 205 \text{ cm}$$

Breadth = 60 cm

$$\begin{aligned} \text{Area of the rectangle} &= (\text{Length} \times \text{Breadth}) \text{ sq units} \\ &= (205 \times 60) \text{ cm}^2 = 12300 \text{ cm}^2 \end{aligned}$$

Q2

Answer :

$$\begin{aligned}\text{Side of the square plot} &= 14 \text{ m} \\ \text{Area of the square plot} &= (\text{Side})^2 \text{ sq units} \\ &= (14)^2 \text{ m}^2 \\ &= 196 \text{ m}^2\end{aligned}$$

Q3

Answer :

$$\begin{aligned}\text{Length of the table} &= 2 \text{ m } 25 \text{ cm} \\ &= (2 + 0.25) \text{ m} \quad (100 \text{ cm} = 1 \text{ m}) \\ &= 2.25 \text{ m} \\ \text{Breadth of the table} &= 1 \text{ m } 20 \text{ cm} \\ &= (1 + 0.20) \text{ m} \quad (100 \text{ cm} = 1 \text{ m}) \\ &= 1.20 \text{ m} \\ \text{Area of the table} &= (\text{Length} \times \text{Breadth}) \text{ sq units} \\ &= (2.25 \times 1.20) \text{ m}^2 \\ &= \left(\frac{225}{100} \times \frac{120}{100}\right) \text{ m}^2 \\ &= 2.7 \text{ m}^2\end{aligned}$$

Q4

Answer :

$$\begin{aligned}\text{Length of the carpet} &= 30 \text{ m } 75 \text{ cm} \\ &= (30 + 0.75) \text{ m} \quad (100 \text{ cm} = 1 \text{ m}) \\ &= 30.75 \text{ m} \\ \text{Breadth of the carpet} &= 80 \text{ cm} \\ &= 0.80 \text{ m} \quad (100 \text{ cm} = 1 \text{ m}) \\ \text{Area of carpet} &= (\text{Length} \times \text{breadth}) \text{ sq units} \\ &= (30.75 \times 0.80) \text{ m}^2 \\ &= \left(\frac{3075}{100} \times \frac{80}{100}\right) \text{ m}^2 \\ &= 24.6 \text{ m}^2\end{aligned}$$

$$\begin{aligned}\text{Cost of } 1 \text{ m}^2 \text{ carpet} &= \text{Rs } 150 \\ \text{Cost of } 24.6 \text{ m}^2 \text{ carpet} &= \text{Rs } (24.6 \times 150) \\ &= \text{Rs } 3690\end{aligned}$$

Q5

Answer :

$$\begin{aligned}\text{Length of the sheet of paper} &= 3 \text{ m } 24 \text{ cm} = 324 \text{ cm} \\ \text{Breadth of the sheet of paper} &= 1 \text{ m } 72 \text{ cm} = 172 \text{ cm} \\ \text{Area of the sheet} &= (\text{Length} \times \text{Breadth}) \\ &= (324 \times 172) \text{ cm}^2 \\ &= 55728 \text{ cm}^2\end{aligned}$$

$$\begin{aligned}\text{Length of the piece of paper required to make 1 envelope} &= 18 \text{ cm} \\ \text{Breadth of the piece of paper required to make 1 envelope} &= 12 \text{ cm} \\ \text{Area of the piece of paper required to make 1 envelope} &= (18 \times 12) \text{ cm}^2 \\ &= 216 \text{ cm}^2\end{aligned}$$

$$\begin{aligned}\text{No. of envelopes that can be made} &= \frac{\text{Area of the sheet}}{\text{Area of the piece of paper required to make 1 envelope}} \\ \Rightarrow \text{No. of envelopes that can be made} &= \frac{55728}{216} = 258 \text{ envelopes}\end{aligned}$$

Q6

Answer :

Length of the room = 12.5 m

Breadth of the room = 8 m

Area of the room = (Length×Breadth)
= (12.5×8) m² = 100 m²

Side of the square carpet = 8 m

Area of the carpet = (Side)²
= 8² m²
= 64 m²

Area of the floor which is not carpeted = Area of the room – Area of the carpet
= (100 – 64) m²
= 36 m²

Q7

Answer :

Length of the road = 150 m = 15000 cm

Breadth of the road = 9 m = 900 cm

Area of the road = (Length×Breadth)
= 15000 × 900 cm²
= 13500000 cm²

Length of the brick = 22.5 cm

Breadth of the brick = 7.5 cm

Area of one brick = (Length×Breadth)
= (22.5 × 7.5) cm²
= 168.75 cm²

Number of bricks = $\frac{\text{Area of the road}}{\text{Area of one brick}} = \frac{13500000}{168.75} = 80000$ bricks

Q8

Answer :

Length of the room = 13 m

Breadth of the room = 9 m

Area of the room = (13×9) m² = 117 m²

Let length of required carpet be x m.

Breadth of the carpet = 75 cm
= 0.75 m (100 cm = 1 m)

Area of the carpet = (0.75×x) m²
= 0.75x m²

For carpeting the room:

Area covered by the carpet = Area of the room
⇒ 0.75x = 117 ⇒ x = 1170.75 ⇒ x = 117 × 43 ⇒ x = 156 m

So, the length of the carpet is 156 m.

Cost of 1 m carpet = Rs 65

Cost 156 m carpet = Rs (156×65)
= Rs 10140

Q9

Answer :

Let the length of the rectangular park be $5x$.

\therefore Breadth of the rectangular park = $3x$

$$\begin{aligned}\text{Perimeter of the rectangular field} &= 2(\text{Length} + \text{Breadth}) \\ &= 2(5x + 3x) \\ &= 16x\end{aligned}$$

It is given that the perimeter of rectangular park is 128 m.

$$\Rightarrow 16x = 128$$

$$\Rightarrow x = \frac{128}{16}$$

$$\Rightarrow x = 8$$

$$\begin{aligned}\text{Length of the park} &= (5 \times 8) \text{ m} \\ &= 40 \text{ m}\end{aligned}$$

$$\begin{aligned}\text{Breadth of the park} &= (3 \times 8) \text{ m} \\ &= 24 \text{ m}\end{aligned}$$

Area of the park = (Length \times Breadth) sq units

$$\begin{aligned}&= (40 \times 24) \text{ m}^2 \\ &= 960 \text{ m}^2\end{aligned}$$

Q10

Answer :

Side of the square plot = 64 m

$$\text{Perimeter of the square plot} = (4 \times \text{Side}) \text{ m} = (4 \times 64) \text{ m} = 256 \text{ m}$$

Area of the square plot = (Side)²

$$= 64^2 \text{ m}^2$$

$$= 4096 \text{ m}^2$$

Let the breadth of the rectangular plot be x m.

Perimeter of the rectangular plot = $2(l+b)$ m

$$= 2(70+x) \text{ m}$$

Perimeter of the rectangular plot = Perimeter of the square plot (Given)

$$\Rightarrow 2(70 + x) = 256$$

$$\Rightarrow 140 + 2x = 256$$

$$\Rightarrow 2x = 256 - 140$$

$$\Rightarrow 2x = 116$$

$$\Rightarrow x = \frac{116}{2} = 58$$

So, the breadth of the rectangular plot is **58 m**.

$$\text{Area of the rectangular plot} = (\text{Length} \times \text{Breadth}) = (70 \times 58) \text{ m}^2 = 4060 \text{ m}^2$$

Area of the square plot - Area of the rectangular plot

$$= (4096 - 4060)$$

$$= 36 \text{ m}^2$$

Q11

Answer :

Total cost of cultivating the field = Rs 71400

Rate of cultivating the field = Rs 35/m²

$$\text{Area of the field} = \frac{\text{Total cost of cultivating the field}}{\text{Rate of cultivating}} = \frac{\text{Rs } 71400}{\text{Rs } 35/\text{m}^2} = 2040 \text{ m}^2$$

Let the length of the field be x m.

$$\text{Area of the field} = (\text{Length} \times \text{Width}) \text{ m}^2 = (x \times 40) \text{ m}^2 = 40x \text{ m}^2$$

It is given that the area of the field is 2040 m².

$$\Rightarrow 40x = 2040$$

$$\Rightarrow x = \frac{2040}{40} = 51$$

$$\therefore \text{Length of the field} = 51 \text{ m}$$

Perimeter of the field = 2(l+b)

$$= 2(51+40) \text{ m}$$

$$= 182 \text{ m}$$

Cost of fencing 1 m of the field = Rs 50

Cost of fencing 182 m of the field = Rs (182×50)

$$= \text{Rs } 9100$$

Q12

Answer :

Let the width of the rectangle be x cm.

Length of the rectangle = 36 cm

Area of the rectangle = (Length × Width) = (36 × x) cm²

It is given that the area of the rectangle is 540 cm².

$$\Rightarrow 36 \times x = 540$$

$$\Rightarrow x = \frac{540}{36}$$

$$\Rightarrow x = 15$$

$$\therefore \text{Width of the rectangle} = 15 \text{ cm}$$

Perimeter of the rectangle = 2(Length + Width) cm

$$= 2(36 + 15) \text{ cm}$$

$$= 102 \text{ cm}$$

Q13

Answer :

Length of the wall = 4 m = 400 cm

Breadth of the wall = 3 m = 300 cm

Area of the wall = (400×300) cm² = 120000 cm²

Length of the tile = 12 cm

Breadth of the tile = 10 cm

Area of one tile = (12×10) cm² = (120) cm²

Number of tiles required to cover the wall = $\frac{\text{Area of the wall}}{\text{Area of one tile}} = \frac{120000}{120} = 1000$ tiles

Cost of 1 tile = Rs 22.50

Cost of 1000 tiles = (1000 × 22.50) = Rs 22500

Thus, the total cost of the tiles is Rs 22500.

Q14

Answer :

Let the length of the rectangle be x cm.

Breadth of the rectangle is 25 cm.

$$\begin{aligned}\text{Area of the rectangle} &= (\text{Length} \times \text{Breadth}) \text{ cm}^2 \\ &= (x \times 25) \text{ cm}^2 \\ &= 25x \text{ cm}^2\end{aligned}$$

It is given that the area of the rectangle is 600 cm^2 .

$$\Rightarrow 25x = 600$$

$$\Rightarrow x = \frac{600}{25} = 24$$

So, the length of the rectangle is 24 cm.

$$\begin{aligned}\text{Perimeter of the rectangle} &= 2(\text{Length} + \text{Breadth}) \text{ units} \\ &= 2(25 + 24) \text{ cm} \\ &= 98 \text{ cm}\end{aligned}$$

Q15

Answer :

$$\begin{aligned}\text{Area of the square} &= \left\{ \frac{1}{2} \times (\text{Diagonal})^2 \right\} \text{ sq units} \\ &= \left\{ \frac{1}{2} \times (5\sqrt{2})^2 \right\} \text{ cm}^2 \\ &= \left\{ \frac{1}{2} \times (5)^2 \times (\sqrt{2})^2 \right\} \text{ cm}^2 \\ &= \left\{ \frac{1}{2} \times 25 \times 2 \right\} \text{ cm}^2 \\ &= \left(\frac{1}{2} \times 50 \right) \text{ cm}^2 = 25 \text{ cm}^2\end{aligned}$$

Q16

Answer :

$$\begin{aligned}\text{(i) Area of rectangle ABDC} &= \text{Length} \times \text{Breadth} \\ &= \text{AB} \times \text{AC} \quad (\text{AC} = \text{AE} - \text{CE}) \\ &= (1 \times 8) \text{ m}^2 \\ &= 8 \text{ m}^2\end{aligned}$$

$$\begin{aligned}\text{Area of rectangle CEFG} &= \text{Length} \times \text{Breadth} \\ &= \text{CG} \times \text{GF} \quad (\text{CG} = \text{GD} + \text{CD}) \\ &= (9 \times 2) \text{ m}^2 \\ &= 18 \text{ m}^2\end{aligned}$$

$$\begin{aligned}\text{Area of the complete figure} &= \text{Area of rectangle ABDC} + \text{Area of rectangle CEFG} \\ &= (8 + 18) \text{ m}^2 \\ &= 26 \text{ m}^2\end{aligned}$$

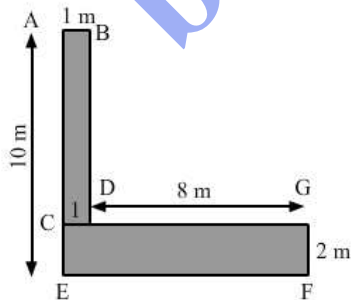

(ii) Area of rectangle AEDC = Length \times Breadth

$$= ED \times CD$$

$$= (12 \times 2) \text{m}^2$$

$$= 24 \text{m}^2$$

Area of rectangle FJIH = Length \times Breadth

$$= HI \times IJ$$

$$= (1 \times 9) \text{m}^2$$

$$= 9 \text{m}^2$$

Area of rectangle ABGF = Length \times Breadth

$$= AB \times AF$$

$$\{(AB = FJ - GJ) \text{ and } AF = EH - (EA + FH)\}$$

$$= (7 \times 1.5) \text{m}^2$$

$$= 10.5 \text{m}^2$$

Area of the complete figure = Area of rectangle AEDC + Area of rectangle FJIH + Area of rectangle ABGF

$$= (24 + 9 + 10.5) \text{m}^2$$

$$= 43.5 \text{m}^2$$

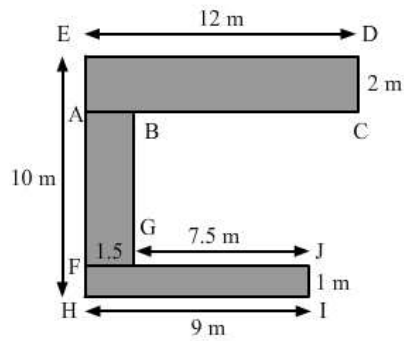

(iii) Area of the shaded portion = Area of the complete figure – Area of the unshaded figure

= Area of rectangle ABCD – Area of rectangle GBFE

$$= (CD \times AD) - (GB \times BF)$$

$$= \{(12 \times 9) - (7.5 \times 10)\} \text{m}^2$$

$$(BF = BC - FC)$$

$$= (108 - 75) \text{m}^2$$

$$= 33 \text{m}^2$$

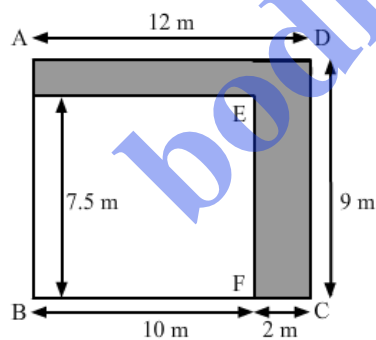

Q17

Answer :

$$\begin{aligned} \text{(i) Area of square BCDE} &= (\text{Side})^2 \\ &= (\text{CD})^2 \\ &= (3)^2 \text{ cm}^2 \\ &= 9 \text{ cm}^2 \end{aligned}$$

$$\begin{aligned} \text{Area of rectangle ABFK} &= \text{Length} \times \text{Breadth} \\ &= \text{AK} \times \text{AB} \quad [(\text{AB} = \text{AC} - \text{BC}) \text{ and } (\text{AK} = \text{AL} + \text{LK})] \\ &= (5 \times 1) \text{ cm}^2 \\ &= 5 \text{ cm}^2 \end{aligned}$$

$$\begin{aligned} \text{Area of rectangle MLKG} &= \text{Length} \times \text{Breadth} \\ &= \text{ML} \times \text{MG} \\ &= (2 \times 3) \text{ cm}^2 \\ &= 6 \text{ cm}^2 \end{aligned}$$

$$\begin{aligned} \text{Area of rectangle JHGF} &= \text{Length} \times \text{Breadth} \\ &= \text{JH} \times \text{HG} \\ &= (2 \times 4) \text{ cm}^2 \\ &= 8 \text{ cm}^2 \end{aligned}$$

$$\begin{aligned} \text{Area of the figure} &= \text{Area of rectangle ABFK} + \text{Area of rectangle MLKG} + \text{Area of rectangle JHGF} \\ &+ \text{Area of square BCDE} \\ &= (9 + 5 + 6 + 8) \text{ cm}^2 \\ &= 28 \text{ cm}^2 \end{aligned}$$

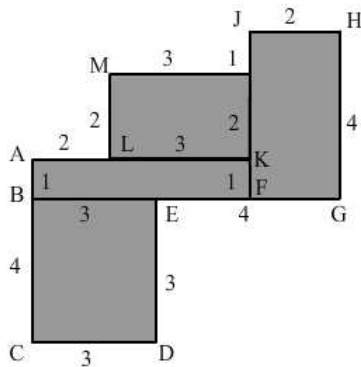

$$\begin{aligned} \text{(ii) Area of rectangle CEFG} &= \text{Length} \times \text{Breadth} \\ &= \text{EF} \times \text{CE} \\ &= (1 \times 5) \text{ cm}^2 \quad (\text{CE} = \text{EA} - \text{AC}) \\ &= 5 \text{ cm}^2 \end{aligned}$$

$$\begin{aligned} \text{Area of rectangle ABDC} &= \text{Length} \times \text{Breadth} \\ &= \text{AB} \times \text{BD} \\ &= (1 \times 2) \text{ cm}^2 \\ &= 2 \text{ cm}^2 \end{aligned}$$

$$\begin{aligned} \text{Area of rectangle HIJG} &= \text{Length} \times \text{Breadth} \\ &= \text{HI} \times \text{IJ} \\ &= (1 \times 2) \text{ cm}^2 \\ &= 2 \text{ cm}^2 \end{aligned}$$

$$\begin{aligned} \text{Area of the figure} &= \text{Area of rectangle CEFG} + \text{Area of rectangle HIJG} + \text{Area of rectangle ABDC} \\ &= (5 + 2 + 2) \text{ cm}^2 \\ &= 9 \text{ cm}^2 \end{aligned}$$

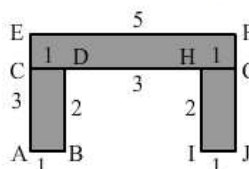

$$\begin{aligned} \text{(iii) In the figure, there are 5 squares, each of whose sides are 6 cm in length.} \\ \text{Area of the figure} &= 5 \times \text{Area of square} \\ &= 5 \times (\text{side})^2 \\ &= 5 \times (6)^2 \text{ cm}^2 \\ &= 180 \text{ cm}^2 \end{aligned}$$

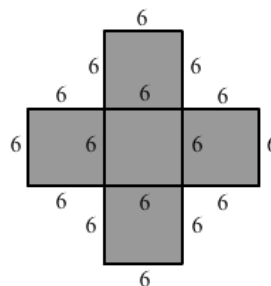

Concepts of Perimeter and Area

Exercise 21E

Q1

Answer :

(b) 28 cm

Let the length and the breadth of the rectangle be $7x$ cm and $5x$ cm, respectively.

It is given that the perimeter of the rectangle is 96 cm.

Perimeter of the rectangle = $2(7x+5x)$ cm

$$\Rightarrow 2(7x + 5x) = 96$$

$$= 2(12x) = 96$$

$$= 24x = 96$$

$$\Rightarrow x = \frac{96}{24} = 4$$

$$\therefore \text{Length} = (7 \times 4) \text{ cm} = 28 \text{ cm}$$

Q2

Answer :

(d) 126 cm

Let length of the rectangle be L cm.

Area of the rectangle = 650 cm^2

Area of the rectangle = $(L \times 13) \text{ cm}^2$

$$\Rightarrow (L \times 13) = 650$$

$$\Rightarrow L = \frac{650}{13} = 50$$

Length of the rectangle is 50 cm

Perimeter of the rectangle = $2(\text{Length} + \text{Breadth}) \text{ cm} = 2(50+13) \text{ cm} = 126 \text{ cm}$

Q3

bodhiyla.com

Answer :

(b) Rs 2340

$$\begin{aligned}\text{Perimeter of the rectangular field} &= 2(\text{Length} + \text{Breadth}) \\ &= 2(34 + 18) \text{ m} = 104 \text{ m}\end{aligned}$$

Cost of fencing 1 metre = Rs 22.50

$$\text{Cost of fencing } 104 \text{ m} = \text{Rs } (22.50 \times 104) = \text{Rs } 2340$$

Q4

Answer :

(b) 16 m

Total cost of fencing = Rs 2400

Rate of fencing = Rs 30/m

$$\text{Perimeter of the rectangular field} = \frac{\text{Total cost}}{\text{Rate}} = \frac{\text{Rs } 2400}{\text{Rs } 30/\text{m}} = 80 \text{ m}$$

Let the breadth of the rectangular field be x m.

$$\text{Perimeter of the rectangular field} = 2(24 + x) \text{ m}$$

$$\Rightarrow 2(24 + x) = 80$$

$$\Rightarrow 48 + 2x = 80$$

$$\Rightarrow 2x = (80 - 48)$$

$$\Rightarrow 2x = 32$$

$$\Rightarrow x = \frac{32}{2} = 16$$

So, the breadth of the rectangular field is 16 m.

Q5

Answer :

(c) 17 m

Let the length and the breadth of the rectangle be L m and B m, respectively.

$$\text{Area of the rectangular carpet} = (L \times B) \text{ m}^2$$

$$\Rightarrow LB = 120 \quad \dots \text{ (i)}$$

$$\text{Perimeter of the rectangular carpet} = 2(L + B)$$

$$\Rightarrow 2(L + B) = 46$$

$$\Rightarrow (L + B) = \frac{46}{2}$$

$$\Rightarrow (L + B) = 23 \quad \dots \text{ (ii)}$$

$$\text{Diagonal of the rectangle} = \sqrt{L^2 + B^2} \text{ m}$$

$$= \sqrt{(L + B)^2 - 2LB} \text{ m}$$

$$= \sqrt{(23)^2 - 240} \text{ m}$$

$$= \sqrt{529 - 240} \text{ m}$$

$$= \sqrt{289} \text{ m}$$

(from equations (i) and (ii))

$$= 17 \text{ m}$$

Q6

Answer :

(a) 48 cm

Let the width and the length of the rectangle be x cm and $3x$ cm, respectively.

Applying Pythagoras theorem:

$$(\text{Diagonal})^2 = (\text{Length})^2 + (\text{Width})^2$$

$$\Rightarrow (6\sqrt{10})^2 = (3x)^2 + (x)^2$$

$$\Rightarrow 360 = 9x^2 + x^2$$

$$\Rightarrow 360 = 10x^2$$

$$\Rightarrow x^2 = \frac{360}{10}$$

$$\Rightarrow x^2 = 36$$

$$\Rightarrow x = \pm 6$$

Since the width cannot be negative, we will neglect -6 .

So, width of the rectangle is 6 cm.

Length of the rectangle = $(3 \times 6) = 18$ cm

Perimeter of the rectangle = $2(\text{Length} + \text{Breadth}) = 2(18 + 6) = 48$ cm

Q7

Answer :

(b) 2 : 1

Let the breadth of the plot be b cm.

Let the length of the plot be x cm.

Perimeter of the plot = $3x$ cm

Perimeter of the plot = $2(\text{Length} + \text{Breadth}) = 2(x + b)$ cm

$$\Rightarrow 2(x + b) = 3x$$

$$2x + 2b = 3x$$

$$\Rightarrow 2b = 3x - 2x$$

$$\Rightarrow 2b = x$$

$$\Rightarrow b = \frac{x}{2}$$

$$\therefore \text{Ratio of the length and the breadth of the plot} = \frac{x}{\left(\frac{x}{2}\right)} = \frac{x}{x} \times 2 = \frac{2}{1}$$

$$\therefore \text{Ratio of the length and the breadth of the plot} = 2 : 1$$

Q8

Answer :

(b) 200 cm^2

$$\text{Area of the square} = \left\{ \frac{1}{2} \times (\text{Diagonal})^2 \right\} \text{ sq units}$$

$$= \left\{ \frac{1}{2} \times (20)^2 \right\} \text{ cm}^2$$

$$= \left\{ \frac{1}{2} \times (20) \times (20) \right\} \text{ cm}^2$$

$$= (20 \times 10) \text{ cm}^2$$

$$= 200 \text{ cm}^2$$

Q9

Answer :

(c) 20 m

Let one side of the square field be x m.

Total cost of fencing a square field = Rs 2000

Rate of fencing the field = Rs 25/m

$$\text{Perimeter of the square field} = \frac{\text{Total cost of fencing the field}}{\text{Rate of fencing the field}} = \frac{\text{Rs } 2000}{\text{Rs } 25/\text{m}} = \frac{2000}{25} \text{ m} = 80 \text{ m}$$

Perimeter of the square field = $(4 \times \text{side}) = 4x$ m

$$\Rightarrow 4x = 80$$

$$\Rightarrow x = \frac{80}{4}$$

$$\Rightarrow x = 20$$

Each side of the field is 20 m.

Q10

Answer :

(b) 22 cm

$$\text{Radius} = \frac{\text{Diameter}}{2} = \frac{7}{2} \text{ cm}$$

$$\begin{aligned} \text{Circumference of the circle} &= 2\pi r = \left(2 \times \frac{22}{7} \times \frac{7}{2}\right) \text{ cm} \\ &= 22 \text{ cm} \end{aligned}$$

Q11

Answer :

(a) 28 cm

Circumference of the circle is 88 cm.

Let the radius be r cm.

It is given that the circumference of the circle is $(2\pi r)$ cm.

$$\Rightarrow 2\pi r = 88$$

$$\Rightarrow 2 \times \frac{22}{7} \times r = 88$$

$$\Rightarrow r = \frac{1}{2} \times \frac{7}{22} \times 88$$

$$\Rightarrow r = 14$$

$$\therefore \text{Radius} = 14 \text{ cm}$$

$$\text{Diameter} = (2 \times \text{Radius}) = (2 \times 14) \text{ cm} = 28 \text{ cm}$$

Q12

Answer :

(b) 110 m

$$\text{Radius of the wheel} = \frac{\text{Diameter}}{2} = \frac{70}{2} = 35 \text{ cm}$$

$$\text{Circumference of the wheel} = 2\pi r = \left(2 \times \frac{22}{7} \times 35\right) \text{ cm} = 220 \text{ cm}$$

The distance covered by the wheel in one revolution is equal to its circumference

$$\text{Distance covered by the wheel in 1 revolution} = 220 \text{ cm}$$

$$\begin{aligned} \therefore \text{Distance covered by the wheel in 50 revolution} &= (50 \times 220) \text{ cm} = 11000 \text{ cm} \\ &= 110 \text{ m} \end{aligned}$$

Q13

Answer :

(d) 80000

Length of the road = 150 m = 15000 cm

Breadth of the road = 9 m = 900 cm

Area of the road = (Length × Breadth)

$$= (15000 \times 900) \text{ cm}^2$$

$$= 13500000 \text{ cm}^2$$

Length of the brick = 22.5 cm

Breadth of the brick = 7.5 cm

Area of one brick = (Length × Breadth)

$$= (22.5 \times 7.5) \text{ cm}^2$$

$$= 168.75 \text{ cm}^2$$

$$\text{Number of bricks} = \frac{\text{Area of the road}}{\text{Area of one brick}}$$

$$= \frac{13500000 \text{ cm}^2}{168.75 \text{ cm}^2} = 80000 \text{ bricks}$$

Q14

Answer :

(b) 24.3 m²

Length of the room = 5 m 40 cm = 5.40 m

Breadth of the room = 4 m 50 cm = 4.50 m

$$\text{Area of the room} = (\text{Length} \times \text{Breadth}) = (5.40 \times 4.50) \text{ m}^2$$

$$= \left(\frac{540}{100} \times \frac{450}{100} \right) \text{ m}^2$$

$$= \left(\frac{27}{5} \times \frac{9}{2} \right) \text{ m}^2$$

$$= \frac{243}{10} \text{ m}^2 = 24.3 \text{ m}^2$$

Q16

Answer :

(b) 64 cm

Side of the square = 16 cm

Perimeter of the square = (4 × Side)

$$= (4 \times 16) \text{ cm}$$

$$= 64 \text{ cm}$$